

VISIBLE LIGHT DETECTOR 412101-B 150mm WAFERS REV H

DESCRIPTION

The 412101-B is a low cost visible light sensor, with a current output which is directly proportional to the light level. It has a built in optical filter to provide a response which is close to the human eye, or “photopic”.

The output current can be converted to a voltage by connecting it in series with a resistor. The dynamic range is determined by the external resistor and power supply (10K and 5V gives a range of 0 to 160 Lux, but can be over 700 Lux with a 1K resistor). The internal dark current cancellation enables high accuracy over the full temperature range, even at relatively low light levels.

FEATURES

- Near human eye photopic response
- High IR rejection – integrated optical filter
- Current output highly linear vs light level
- Temperature stable
- Integrated high gain photo-current amplifier
- Dark-current cancellation

APPLICATIONS

- Dawn/dusk sensing (e.g. CCTV)
- Security lighting
- Display backlighting in laptops, mobile phones, LCD TVs
- Night-lights

1.0 BASIC APPLICATION & TEST CIRCUIT

Figure 1

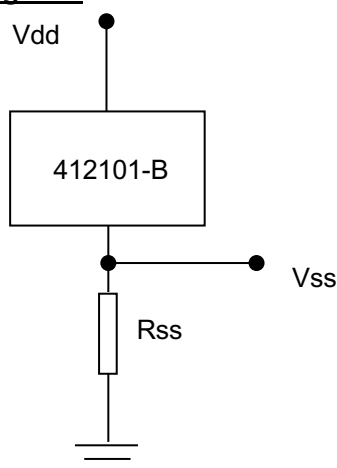

Pin Description

Vdd – Positive terminal
Vss – Negative terminal

See section 7.0 for grind and saw details

2.0 ABSOLUTE MAXIMUM RATINGS

PARAMETER	RATING	UNITS
Supply input voltage	-0.6 to 10	V
Supply current	Internally limited	mA
Operating Temperature, T _o	-40°C to +85°C *	°C
Storage Temperature, T _s	-40°C to +100°C	°C

* The light sensor will function up to +105°C but dark current will have to be taken into consideration. Note that dark current typically doubles every 9.5°C.

Note: During final testing it may be necessary for the device to be tested to determine the orientation before executing the final test sequence. See section 6 for test conditions to be used.

3.0 ELECTRICAL SPECIFICATION

The following parameters apply over the operating temperature range -40°C to $+85^{\circ}\text{C}$, and with $R_{SS}=10\text{ K-Ohms}$ and $V_{DD}=5\text{V}$, as per figure 1. The 412101-B is available in 2 variants – determined by the tolerance of their output current. The table below shows the range of output currents, for specific lighting conditions, for each variant.

Parameter	Symbol	Test Conditions	Min	Typ	Max	Units
Infra-red response		900 nm	0	1	5	% of peak
Min. operating voltage	$V_{DD} - V_{SS}$	$I_{SS} = 250\mu\text{A}$ $I_{SS} = 100\mu\text{A}$		2.1 1.6	2.6 2	V V
Output Current						
+/- 25%	I_{SS}	200 Lux 100 Lux 10 Lux	187.5 93.8 9.4	250 125 12.5	312.5 156.3 15.6	μA μA μA
+/- 40%	I_{SS}	200 Lux 100 Lux 10 Lux	150 75 7.5	250 125 12.5	350 175 17.5	μA μA μA
Dark Current	I_{DRK}	0 Lux, $T_a = 25^{\circ}\text{C}$ 0 Lux, $T_a = 65^{\circ}\text{C}$ 0 Lux, $T_a = 85^{\circ}\text{C}$		5 100 500	10 240	nA nA nA
Gain Linearity			-10		10	%
Peak Spectral Response				520		nm
Sensitive Area				0.054		mm^2
Useable light range		R_{SS} & V_{DD} dependant	0 to 750	0 to 1000		Lux

Note that with a lower R_{SS} resistance, the linear light response range can be greatly increased. See section 3.1.

3.1 Selection of Rss

The 412101-B can be used over a range of lighting conditions by selecting a suitable value of Rss (see figure 1), or by varying Vdd. Also, there is a lower gain version of this device available, the 412102, which is designed to work at higher light levels. This table summarises how to select values of Rss, and shows which device (412101-B or 412102) is suitable for each desired application. The graph below also illustrates the usable ranges of both the 412101-B and 412102, with 1K Ω , 10K Ω and 25K Ω resistors. Note that for these examples Vdd is fixed at 5V.

Light Range	412101-B	412102
0 to 80 Lux	25K Ω	
0 to 160 Lux	10K Ω	
0 to 750 Lux	1K Ω	25 K Ω
0 to 1700 Lux		10 K Ω
0 to 6000 Lux		1 K Ω

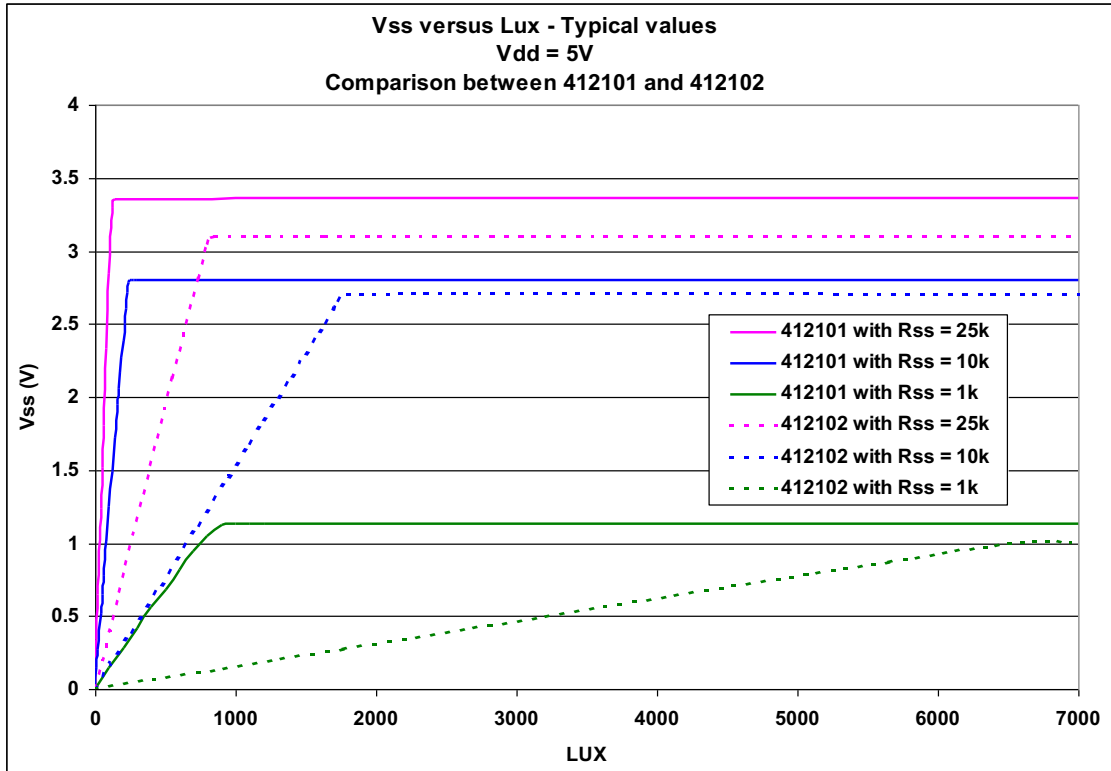

3.2 Characteristic Curves

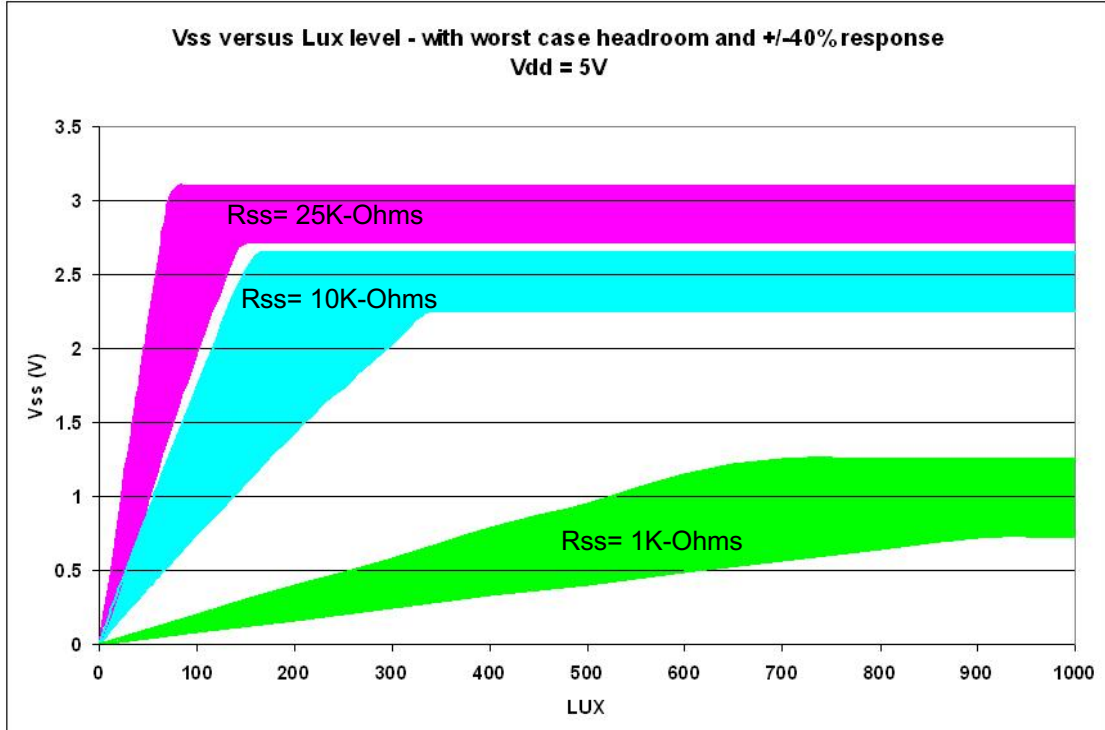
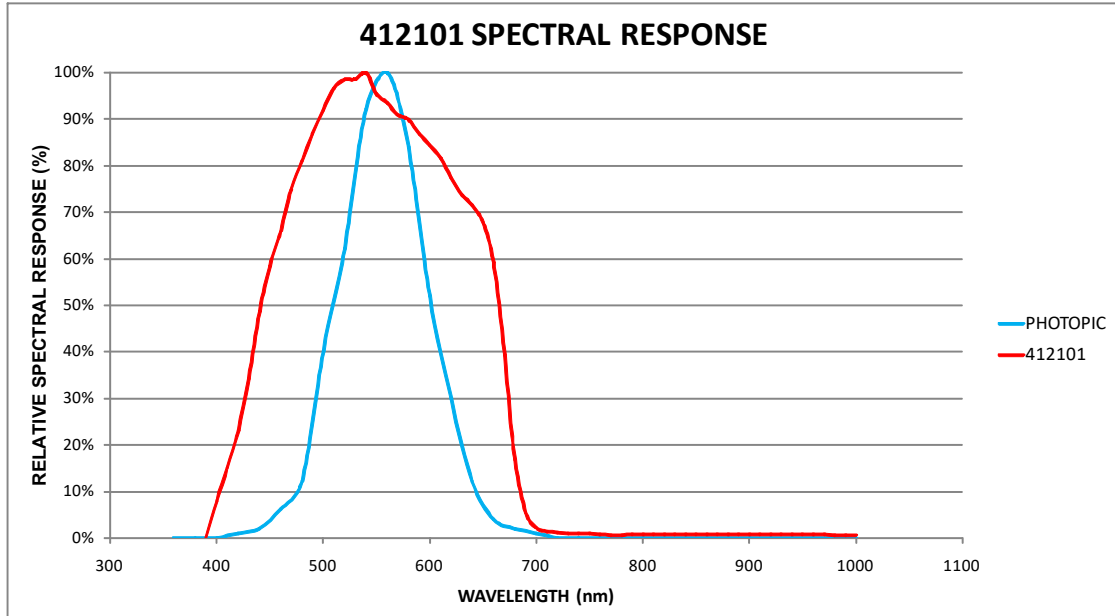

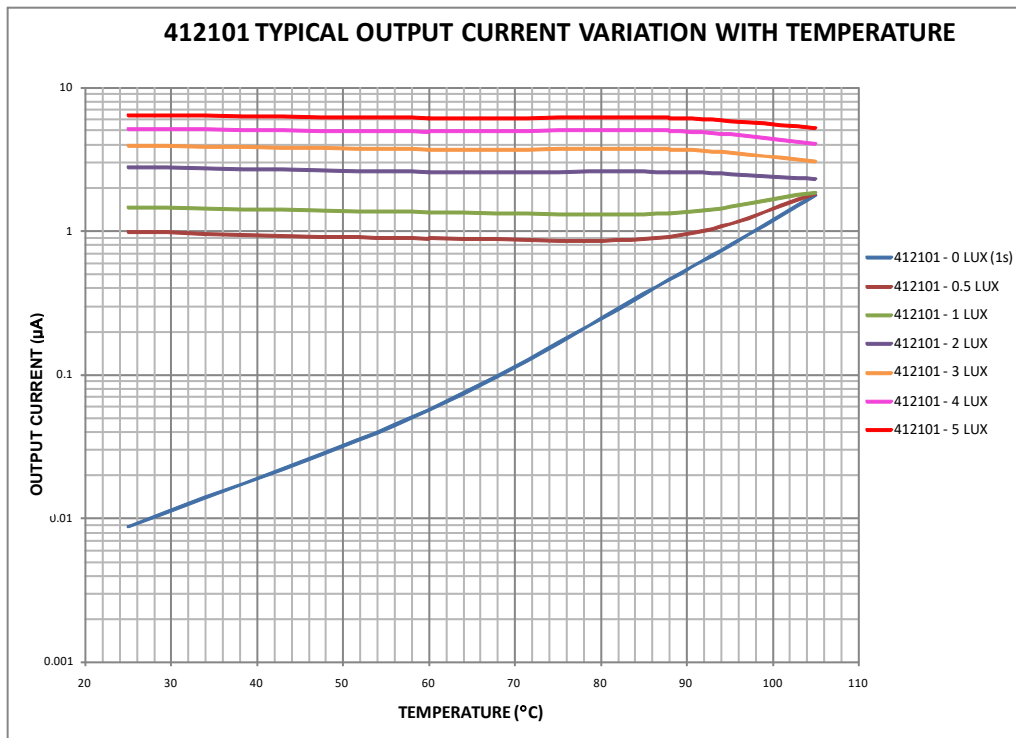
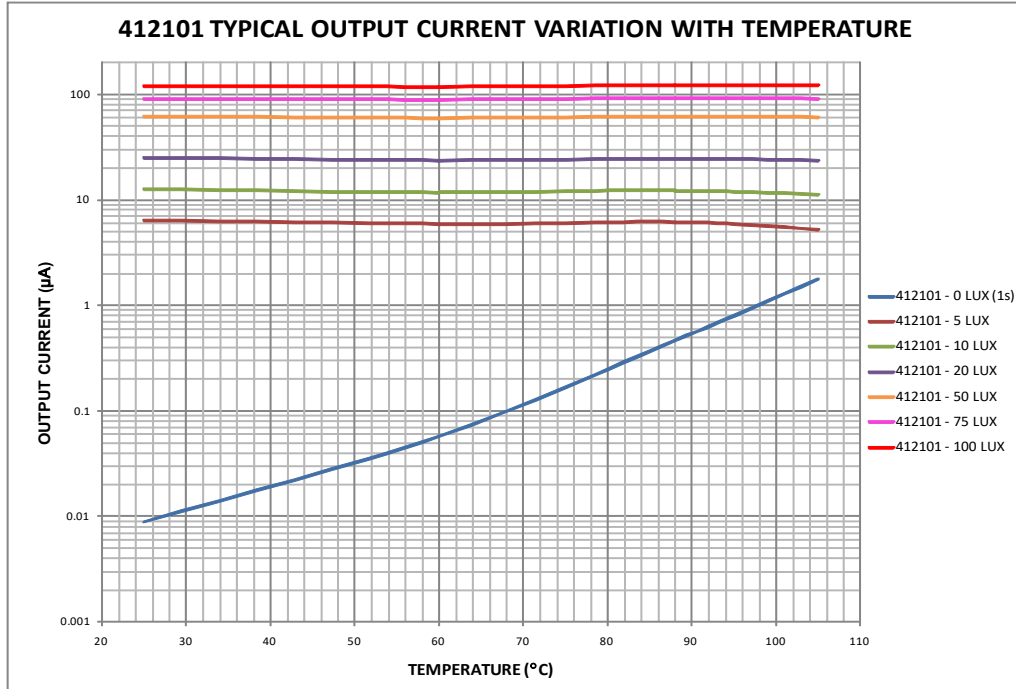

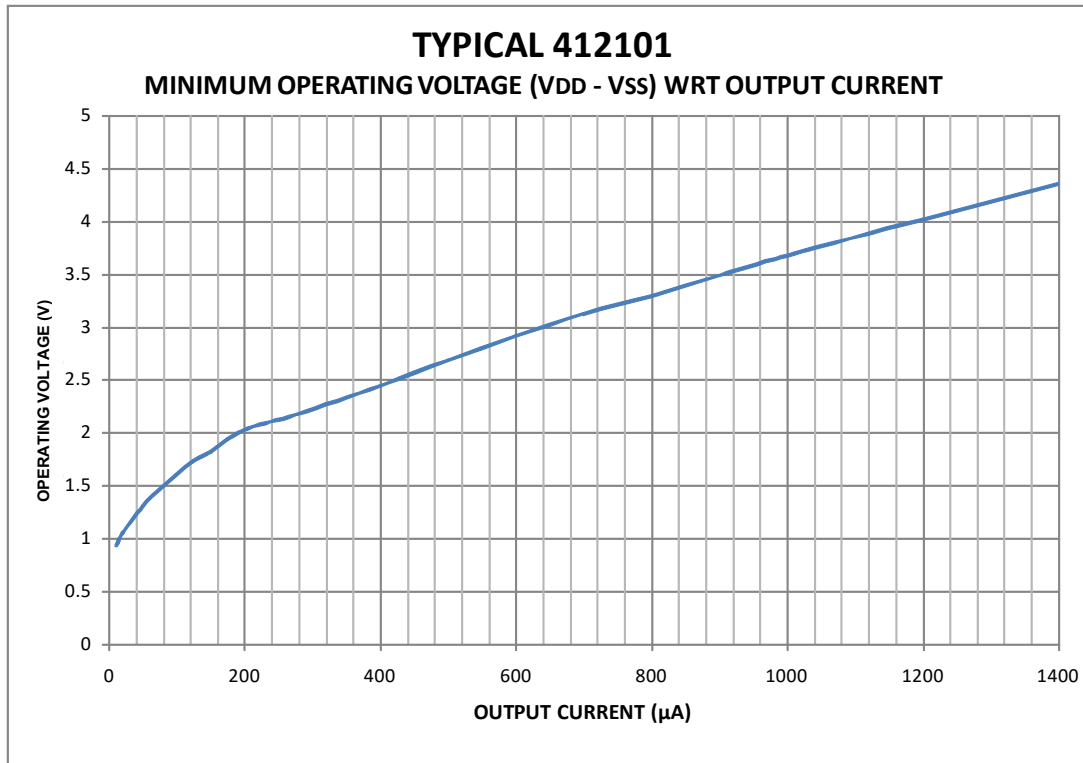

4.0 Application Examples

Automatic Night Light

Fig 2 This circuit shows the 412101-B in an Automatic Night Light application.

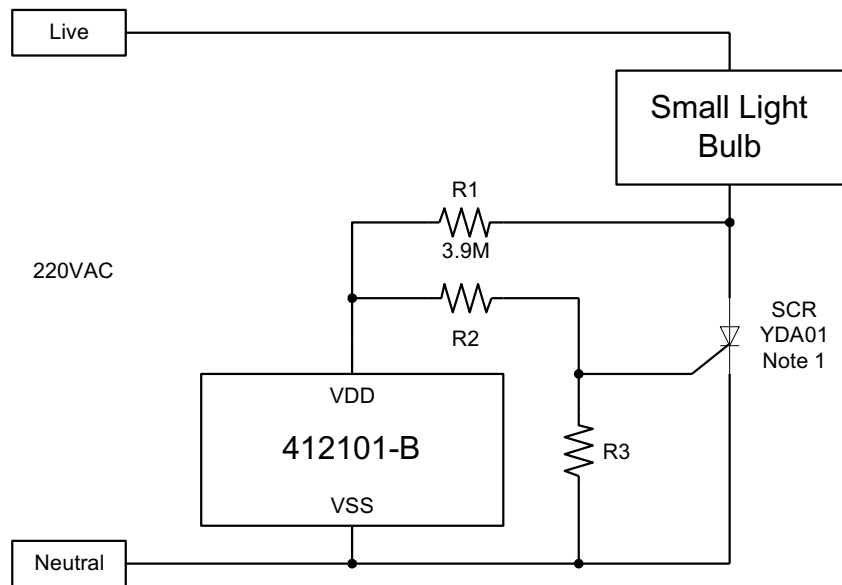

Fig 2

Note 1 This circuit requires a sensitive gate SCR, with $igt(TYP)$ less than $10 \mu A$

The Lamp current is switched by a sensitive gate SCR. The typical gate current of the SCR should be less than $10 \mu A$. When the light is above threshold, current flows between the Vdd and Vss pins of the ASIC which diverts current away from the gate of the SCR. The light switching threshold can be adjusted by choosing different values for R2 and R3.

LED Drivers

Fig 3 is a very simple low cost circuit using the 412101-B to switch an LED.

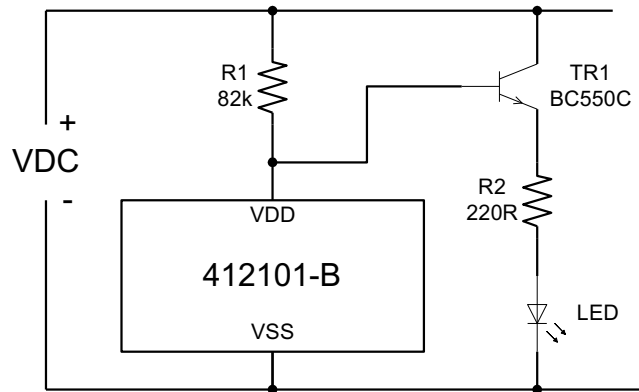

Fig 3

As the light increases, current flows between the Vdd and Vss pins of the ASIC which pulls down the base of TR1. In dark conditions R1 supplies current to the base of TR1 to switch on the LED. The base current of TR1 must be small compared to the photo current. This circuit should only be used when the current in the LED is less than 10mA. The DC current gain (hfe) of TR1 should be > 400 to minimise the base current. The BC550C or equivalent is a suitable transistor for TR1. This circuit is not suitable for VDC < 4V because of the headroom required for the LED and TR1. R1 should be adjusted by customers to obtain the switching threshold to suit the application. This circuit does not have a sharp switching threshold. The LED brightness decreases over a range of about 30 Lux as the ambient light level increases towards the cut-off point. The LED current will switch off completely when R1 is pulled down below about 2.5V. The advantage of this circuit is that it has the smallest number of components.

Fig 4 is a general purpose LED driver.

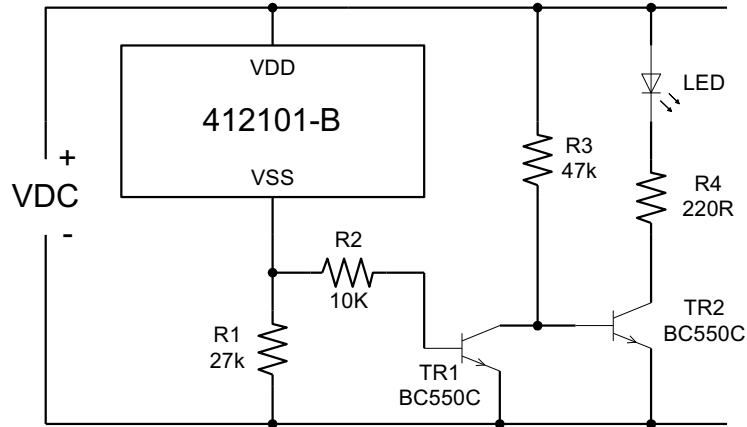

Fig 4

The LED switches ON when the light is less than the switching threshold (Slux). The base current of TR1 will affect the switching threshold. To minimise this effect the base current into TR1 should be less than $10\mu\text{A}$ under all conditions of temperature and supply voltage. When the ambient light $> \text{Slux}$ TR1 pulls down R3 and switches off TR2. For battery operated applications low current drain is important and the value of R3 should be as high as possible so that when the LED is off the circuit quiescent current is low. Slux is controlled by R1 and the base emitter voltage of TR1. R2 limits the base current into TR1 to prevent excess current with high illumination. R4 controls the LED current.

Fig 5 In this circuit the LED switches ON when the light is above the switching threshold Slux.

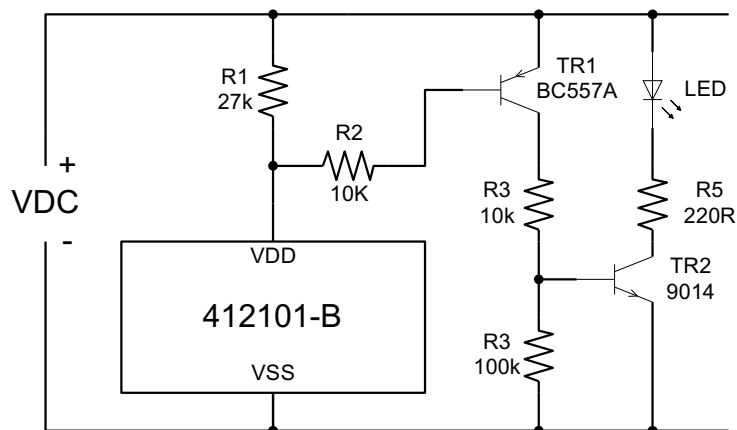

Fig 5

The value of R3 in this circuit can be lower than that in Figure 4 because the current in TR1 is switched off in low light conditions.

Relay Drivers

Fig 6 The relay coil is energised when the light < Slux.

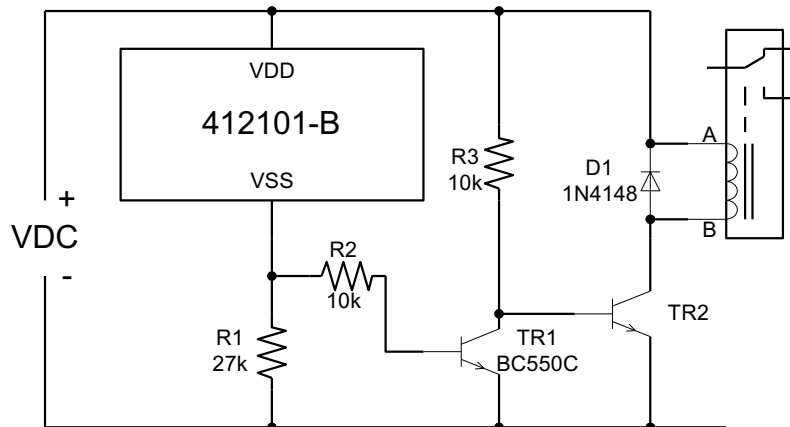

Fig 6

The Slux threshold is set by R1 in the same way as explained in the description for circuit figure 5. For battery operated circuits, the hfe of TR2 should be high to allow a high value for R3. The hfe of TR1 should be high so that a low base current will be able to pull R3 down.

Example:

VDC = 6V, relay coil resistance = 100R. Min hfe of TR2 = 100, min hfe of TR1 = 200

Coil current = 56mA. Min base current to switch on TR2 = 0.56mA. so R3 = 10K.

Min base current of TR1 = $0.56\text{mA}/200 = 2.8\mu\text{A}$.

With the above value for R3, the quiescent current when the relay is off would be around 0.6mA which might be too high for some battery operated circuits.

Fig 7 The relay coil is energised when light > Slux.

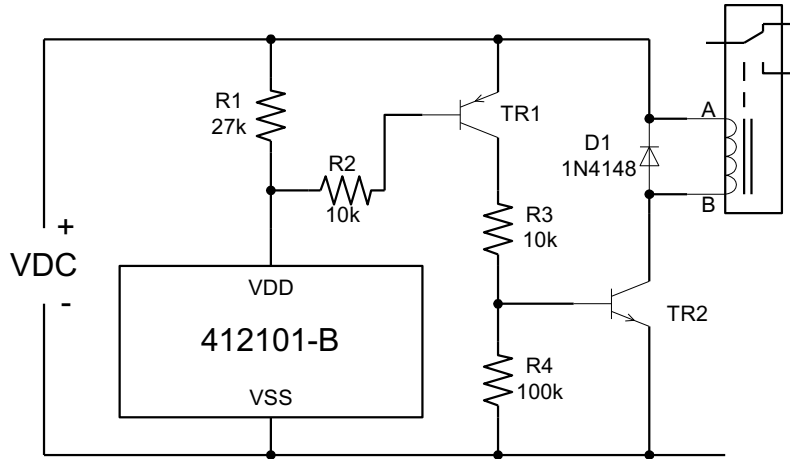

Fig 7

In this case the quiescent current is low in dark conditions because TR1 is switched OFF at the same time as TR2 and the relay coil. The customer can control the current to the application and the quiescent current by choosing a normally open (NO) or normally closed (NC) relay.

Interface Circuit Examples

Fig 8 shows an interface to a microprocessor.

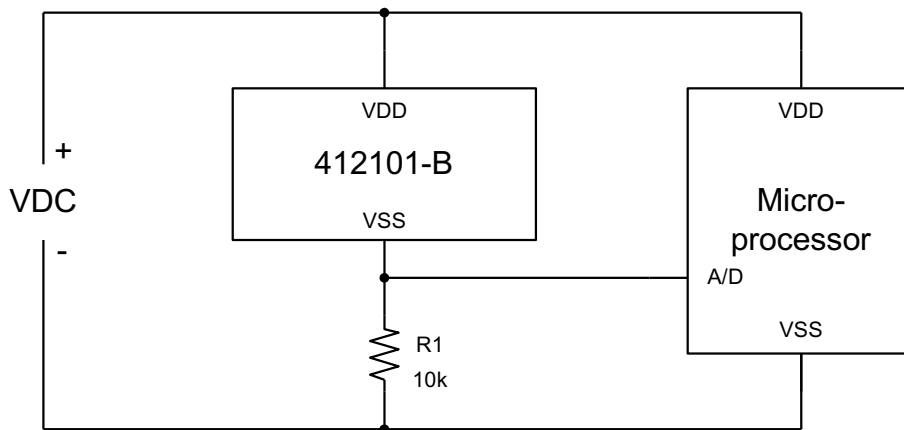

Fig 8

The voltage across R1 varies linearly with the illumination of the sensor. The current between the Vdd and Vss pins is approximately 1.25µA/lux, so with a 10K resistor the voltage at the A/D input will be 12.5mV per lux. The 412101-B was designed for low lux applications and the headroom required between Vdd and Vss becomes a problem at higher lux levels. These parts are not ideally suited to control room lighting applications especially if the microprocessor supply voltage is low. For higher lighting applications such as the control of

room ambient lighting or backlighting applications for TVs, computers or mobile phones then the 412102 should be used (see section 3.1).

Fig 9 This circuit uses a transistor to provide a light level switching interface between the 412101-B and CMOS logic.

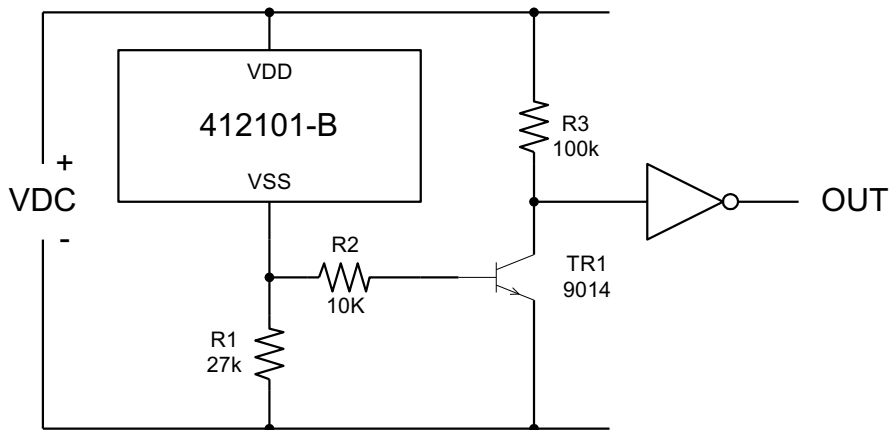

Fig 9

The switching threshold is set by R1 and the base of TR1 as explained for previous circuit examples. The OUT signal will be high when the illumination is above the threshold and low when it is below the threshold. Using a buffer instead of an inverter will change the polarity of the OUT signal

Fig 10 This circuit uses a comparator (or op-amp) to provide a level switching interface for the 412101-B.

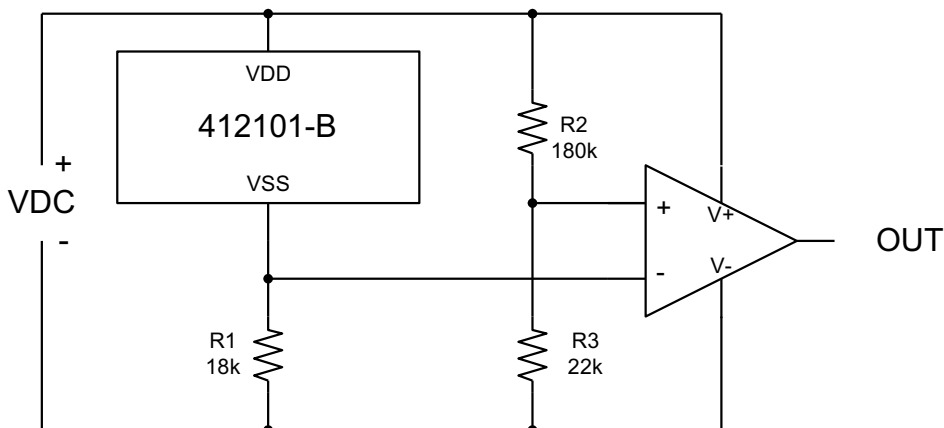

Fig 10

OUT will be high when the voltage at Vss < 0.1*Vdd.

Fig 11 Same as Fig 10 except that OUT will be high when the voltage $V_{ss} > 0.1 \cdot V_{DD}$

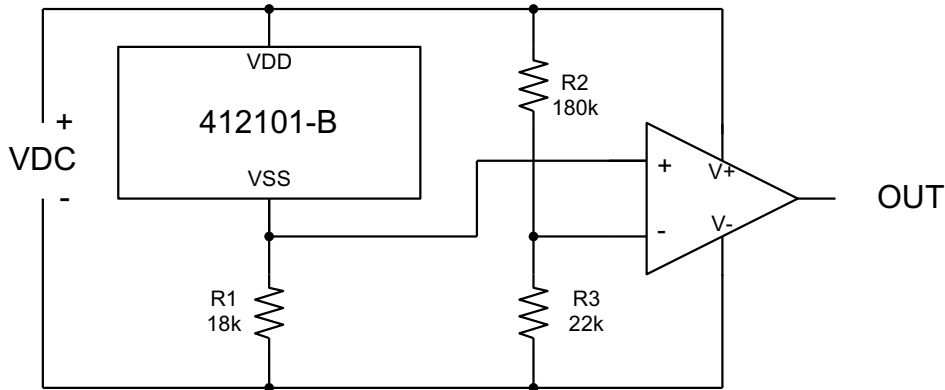

Fig 11

Fig 12 The op-amp circuit amplifies the output voltage at V_{ss} . $V_{OUT} = (1 + R3/R2) I_{photo} \cdot R1$

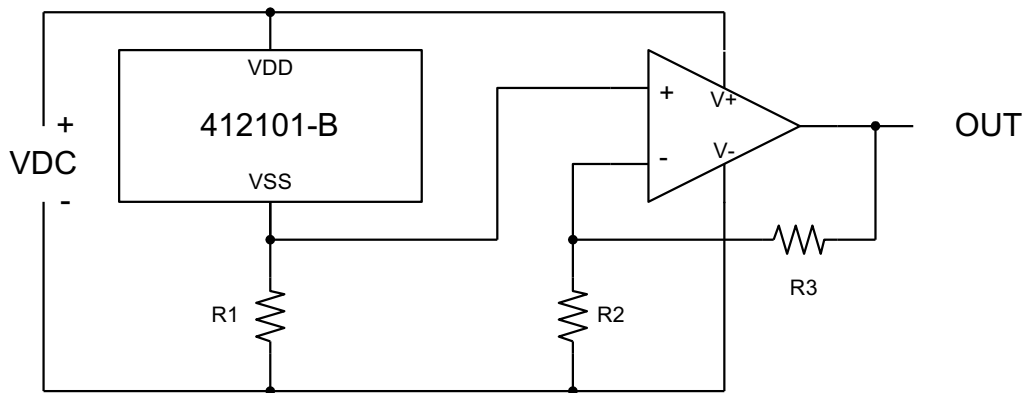

Fig 12

5.0 ORDERING INFORMATION

To order 412101B wafers, please use code in the following table:

	Options	Ordering Code
Nominal Response	1.25 μ A/Lux	412101B
Die Thickness	300 μ m 675 μ m	G NG
Output Current Tolerance	+/- 25% +/- 40%	25 40
Supply Format	Bare die, unsawn wafer Bare die, sawn wafer	D1 D2

Example:

To order sawn wafers, 300 μ m thick, with a tolerance of +/- 40% then use the ordering code:

412101B-G-40-D2.

6.0 Reverse testing of 412101B to determine device orientation

If the device require to be tested to determine the pin orientation before executing the final test sequence, then the following test conditions are to be used in a dark test environment :

Force 0.6V - measure current with a **maximum current limit of 100uA.**

If the device reaches 100uA then the V_{SS} pin is connected high.

If the device does not reach 100uA then the V_{DD} pin is connected high.

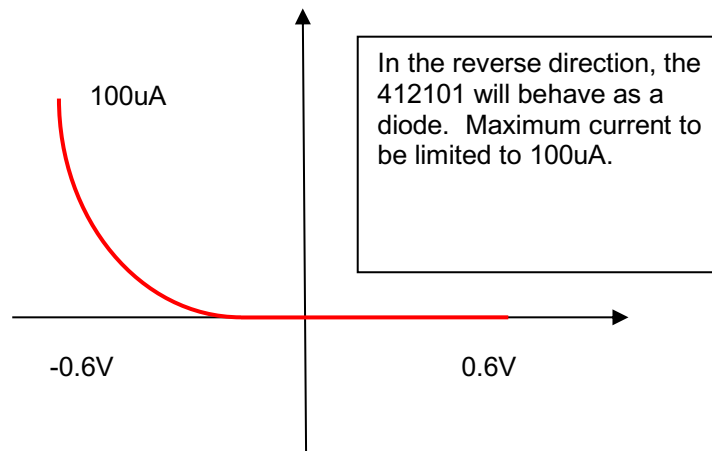

7.0 GRIND, SAW AND PACKAGING INFORMATION

7.1 GRIND

If purchasing unground, unsawn wafers, then it is recommended that the wafers should be ground down from 675 μm down to 300 μm thick.

7.2 SAW

Die stepping pitch is 0.785mm x 0.673mm with 75 μm saw channel. Total number of die per wafer is 30575.

7.3 PACKAGING

Bond pad location as viewed on wafer with major flat to the bottom. Bond pads are 100 μm x 100 μm .

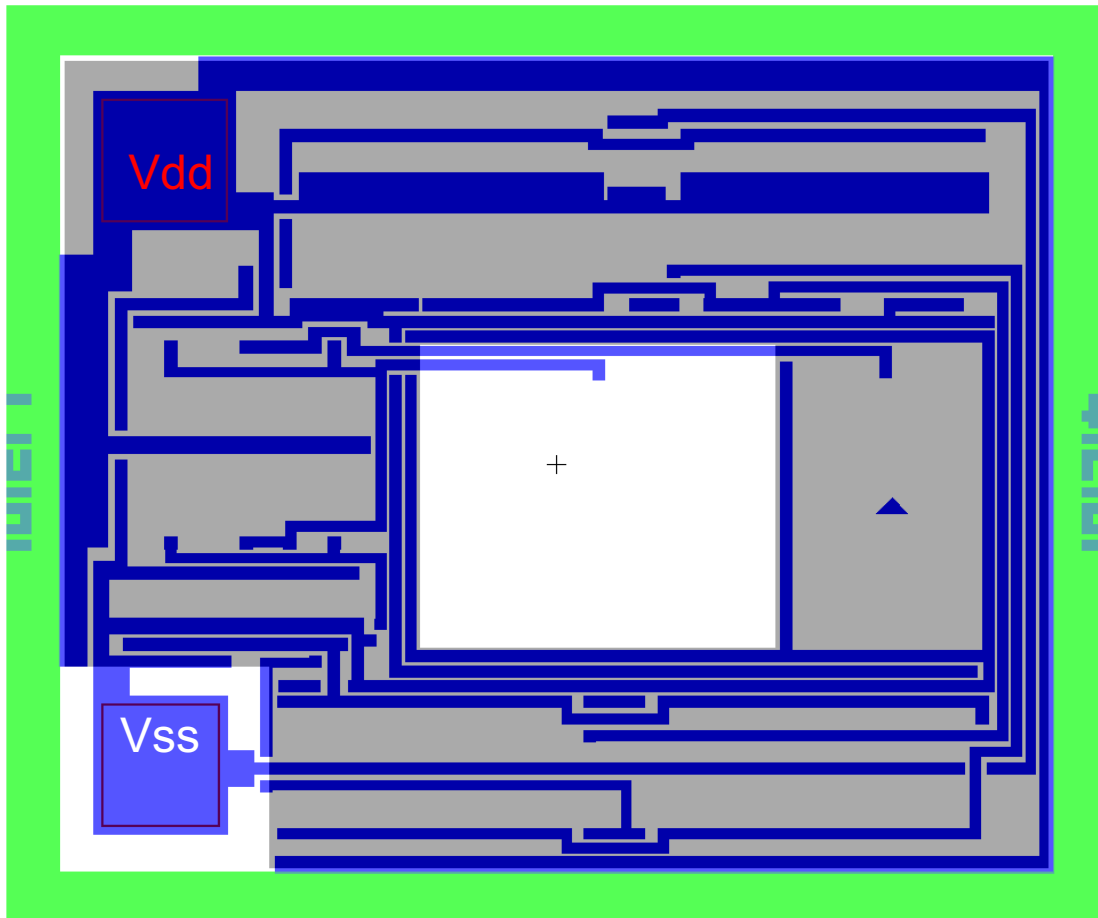

FOR LED STYLE PACKAGES

Vdd bond pad must be connected to the package leadframe with the Vss bond pad connected to the isolated post

